

MUSIKINSTRUMENTENGROSSHANDEL
 RUDOLF HAAS
 A-3430 TULLN, BAHNHOFSTR. 64-68
 TEL. 02272142 48

ROAD TECHNICAL SERVICE INFORMATION

January, 1979

EINGEGANGEN 12. April 1979

ROAD PART NUMBER	MODELS	DESCRIPTION	
1) 200-500B-00	220/440 Power Pack, 115B0, 11BB0, 212L0	Preamp	Schematic
2) 300-500B-00	220/440 Power Pack, 115B0, 11BB0, 212L0	Preamp	Component locator
3) 200-5011-00	220/440 Power Pack	5 Band Graphic EQ	Schematic
4) 300-5011-00	220/440 Power Pack	5 Band Graphic EQ	Component locator
5) 003-0002-00	220 Power Pack, 112L, 212L, 115LH, 115B 115B0, 11BB0, 212L0	Interconnect	Block diagram
6) 003-0000-00	440 Power Pack	Interconnect	Block diagram
7) 200-5007-00	220 Power Pack, 112L, 212L, 115LH, 115B 115B0, 11BB0, 212L0	100 Watt Power amp	Schematic
8) 300-5007-00	220 Power Pack, 112L, 212L, 115LH, 115B 115B0, 11BB0, 212L0	100 Watt Power amp	Component locator
9) 200-5009-00	440 Power Pack	200 Watt Power amp	Schematic
10) 300-5009-00	440 Power Pack	200 Watt Power amp	Component locator
11) 200-5010-00	115B	Bass preamp	Schematic
12) 300-5010-00	115B	Bass preamp	Component locator
13) 200-5010-01	112L, 212L, 115LH	Lead preamp	Schematic
14) 300-5010-01	112L, 212L, 115LH	Lead preamp	Component locator

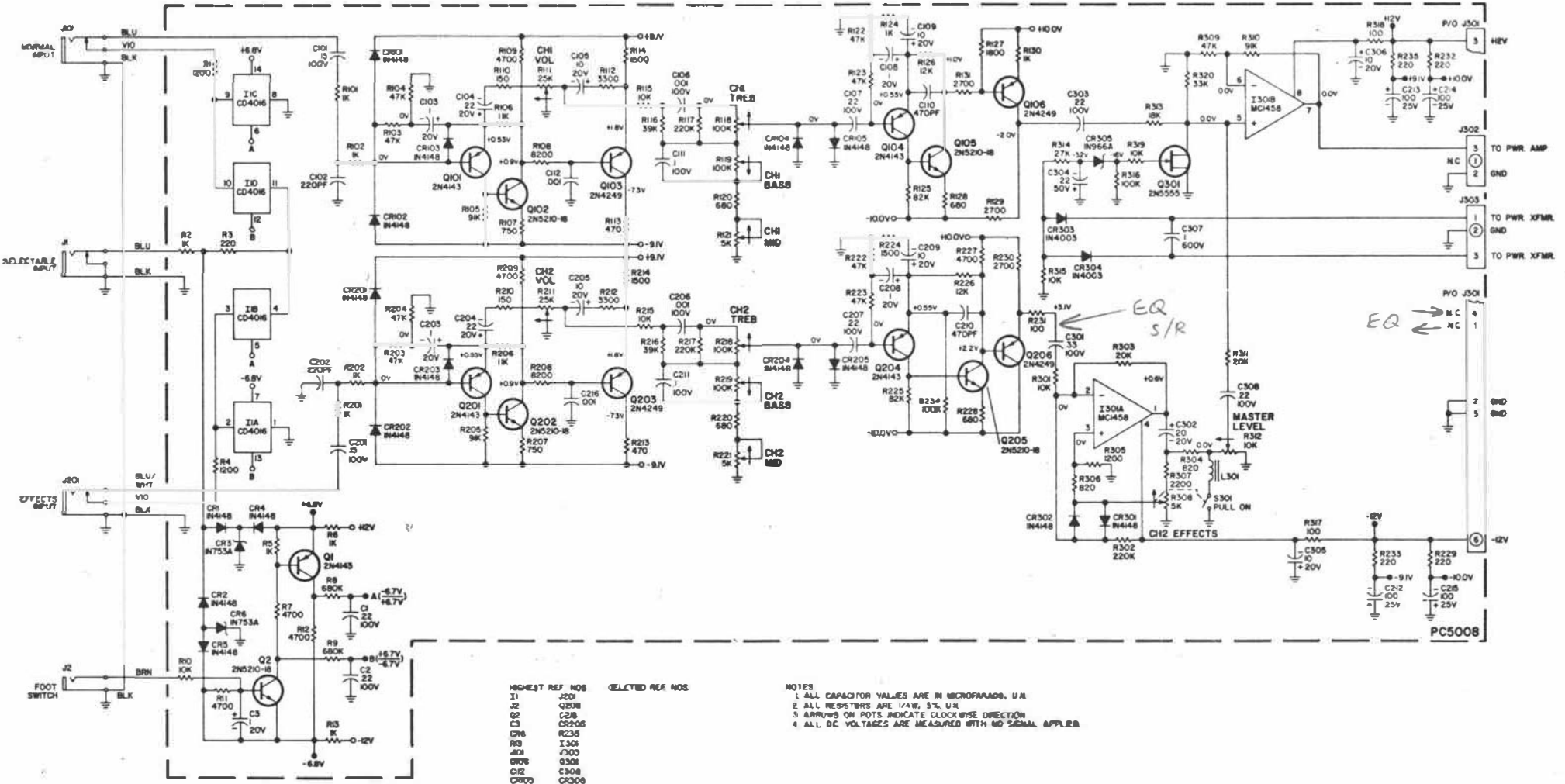

- | | | |
|-----------------|-----------------|---|
| HIGHEST REF NOS | DELETED REF NOS | NOTES |
| J1 | J20 | 1 ALL CAPACITOR VALUES ARE IN MICROFARADS, U.M |
| J2 | Q208 | 2 ALL RESISTORS ARE 1/4W, 5% U.R |
| Q2 | C28 | 3 ARROWS ON POTS INDICATE CLOCKWISE DIRECTION |
| C3 | CR205 | 4 ALL DC VOLTAGES ARE MEASURED WITH NO SIGNAL APPLIED |
| CR6 | RC36 | |
| R3 | I301 | |
| J01 | J003 | |
| CR06 | Q301 | |
| Q12 | C308 | |
| CR00 | CR006 | |
| R31 | A320 | |
| | L30 | |
| | S30 | |

REV	CC	DATE	BY	DESCRIPTION	ITEM
1	0030	11-75	JS	Road	ROAD ELECTRONICS, INC. P.O. Box 931 Riverside, CA 92504 (714) 512-1110
				SCHILL	SC PREAMP/EFFECTS
				NONE	004-5008-00 1 of 1

ROAD 5011 GRAPHIC

NOTES

1. ALL CAPACITOR VALUES ARE IN MICROFARADS U.M.
2. ALL RESISTORS ARE 1/4 WATT UNLESS NOTED.
3. ALL RESISTANCE VALUES ARE IN OHMS U.M.

HIGHEST REF NOS

- R 23
- C 15
- IC 6

DELETED REF NOS

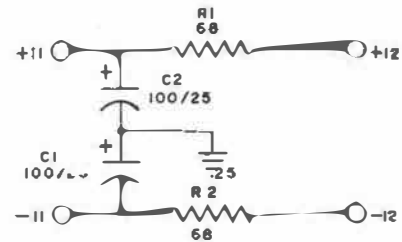
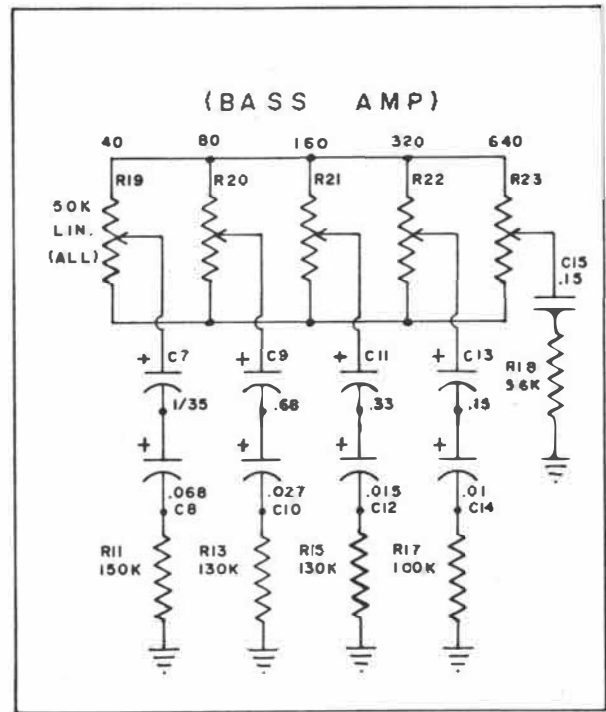
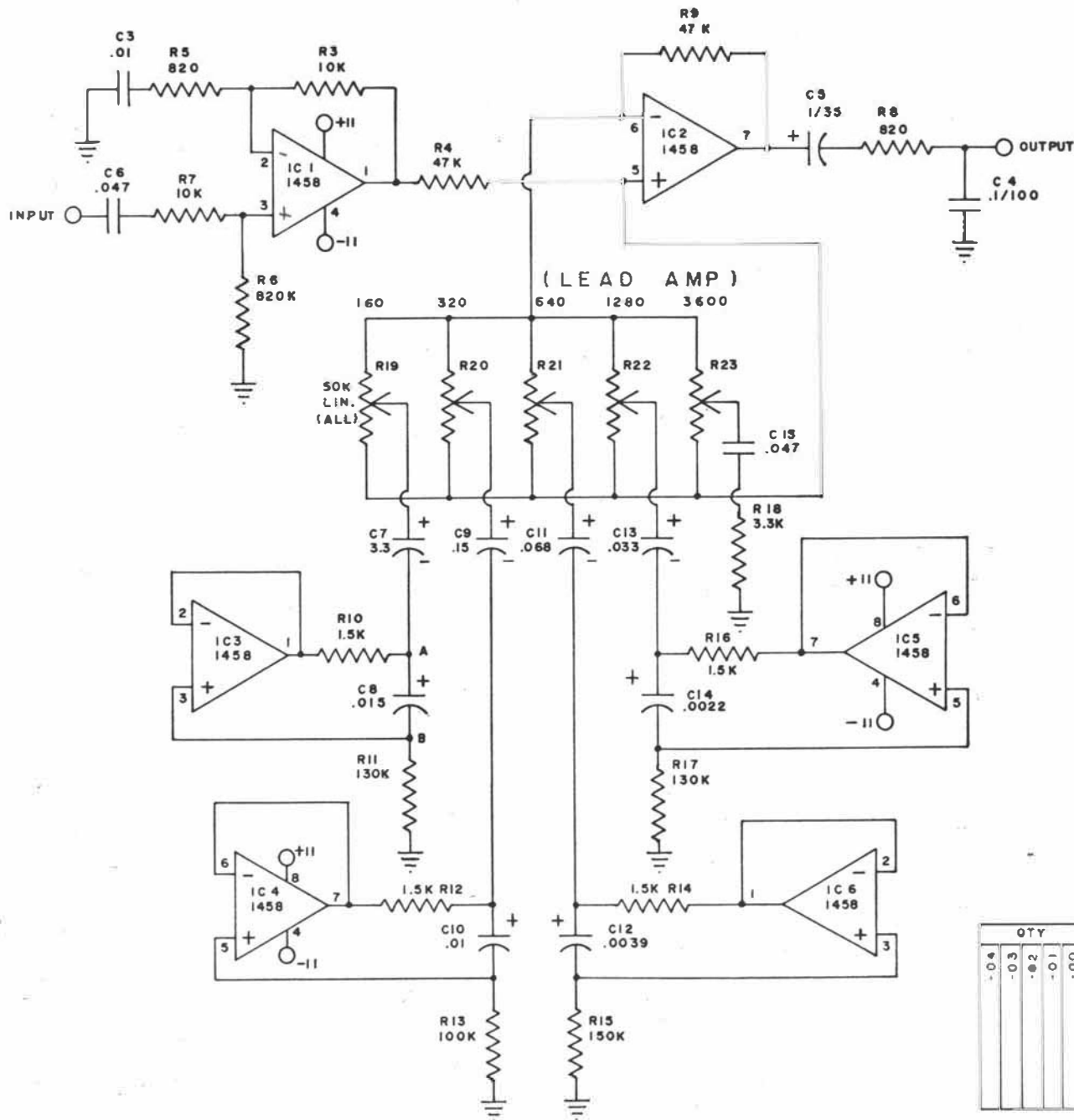

QTY		P/N			DESCRIPTION		ITEM
REV	C.O	DATE	BY	ROAD			ROAD ELECTRONICS, INC 11631 W EXPOSITION BLVD LOS ANGELES, CAL 90064 (213) 473-6761
.04				TOLERANCES UNLESS OTHERWISE SPECIFIED: .010 XX-.003 MLS±.003 L±.019			
.05				DRN	DMS	DATE 10/78	ROAD 5011 GRAPHIC
.02				CHK		DATE	(BASE & LEAD MODELS)
.01				CHK		DATE	
.00				SCALE	NONE	P/N	SMT 1 OF 1 REV

NOTE: ON SELF CONTAINED MODELS
DELETE EQ 5011

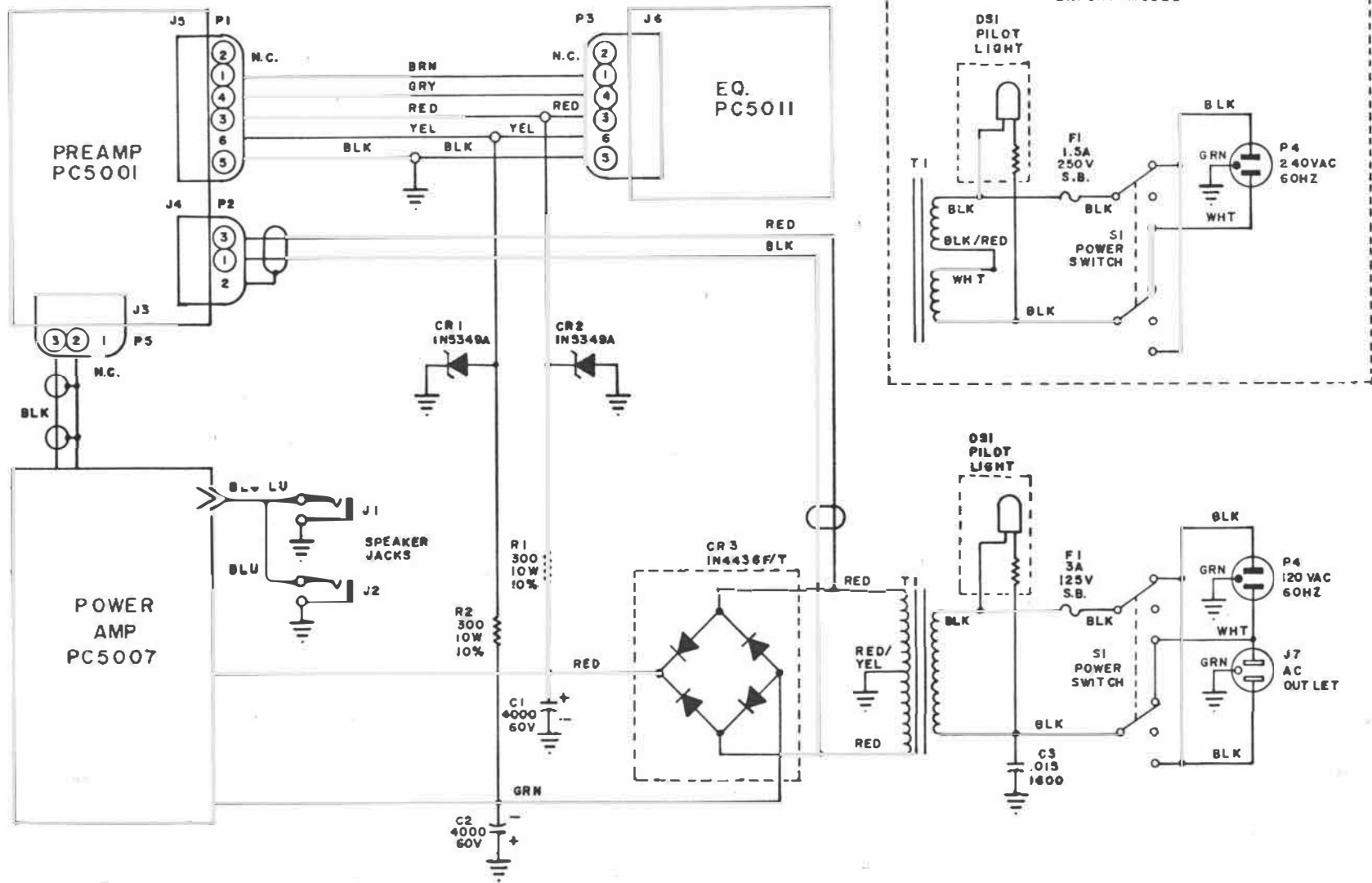

HIGHEST REF. NOS. DELETED REF. NOS.

- DS1
- P5
- J7
- T1
- F1
- S1
- CR3
- C3
- R2

NOTES

1. ALL CAPACITOR VALUES ARE IN MICROFARADS, U.M.

QTY	P/N	DESCRIPTION	ITEM
REV	C.O.	DATE	BY
ROAD			
ROAD ELECTRONICS, INC. 11631 W. EXPOSITION BLVD. LOS ANGELES, CAL 90064 (213) 473-6751			
TOLERANCES U.M. LINEAR-XXX±.00 XX±.05 HL±.006 L±.1*			
DRAWN	OMS	DATE 10/78	
CHEK		DATE	
CHEK		DATE	
SCALE	NONE	P/N 003-0002-00	SHT OF 1 REV 0

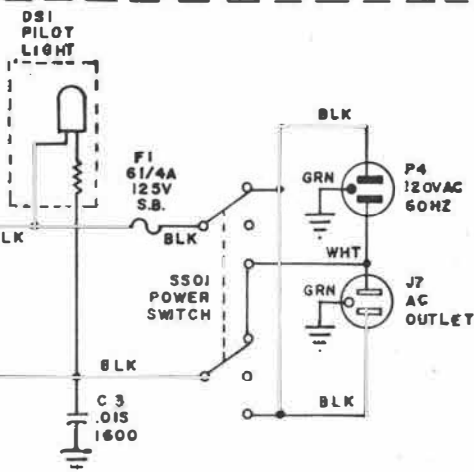
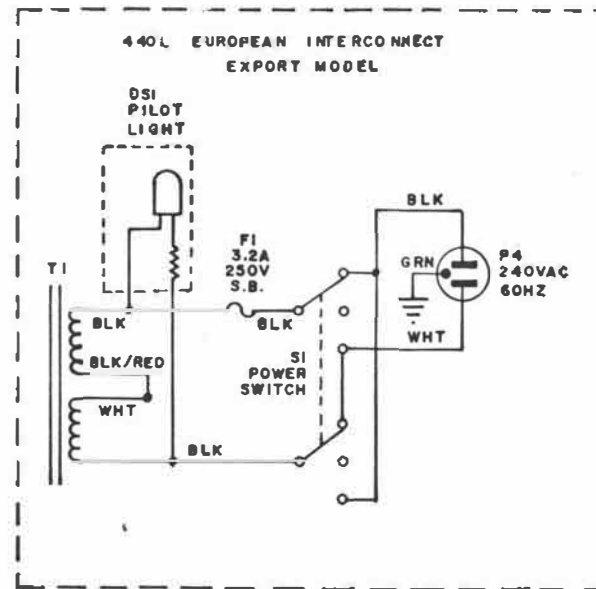
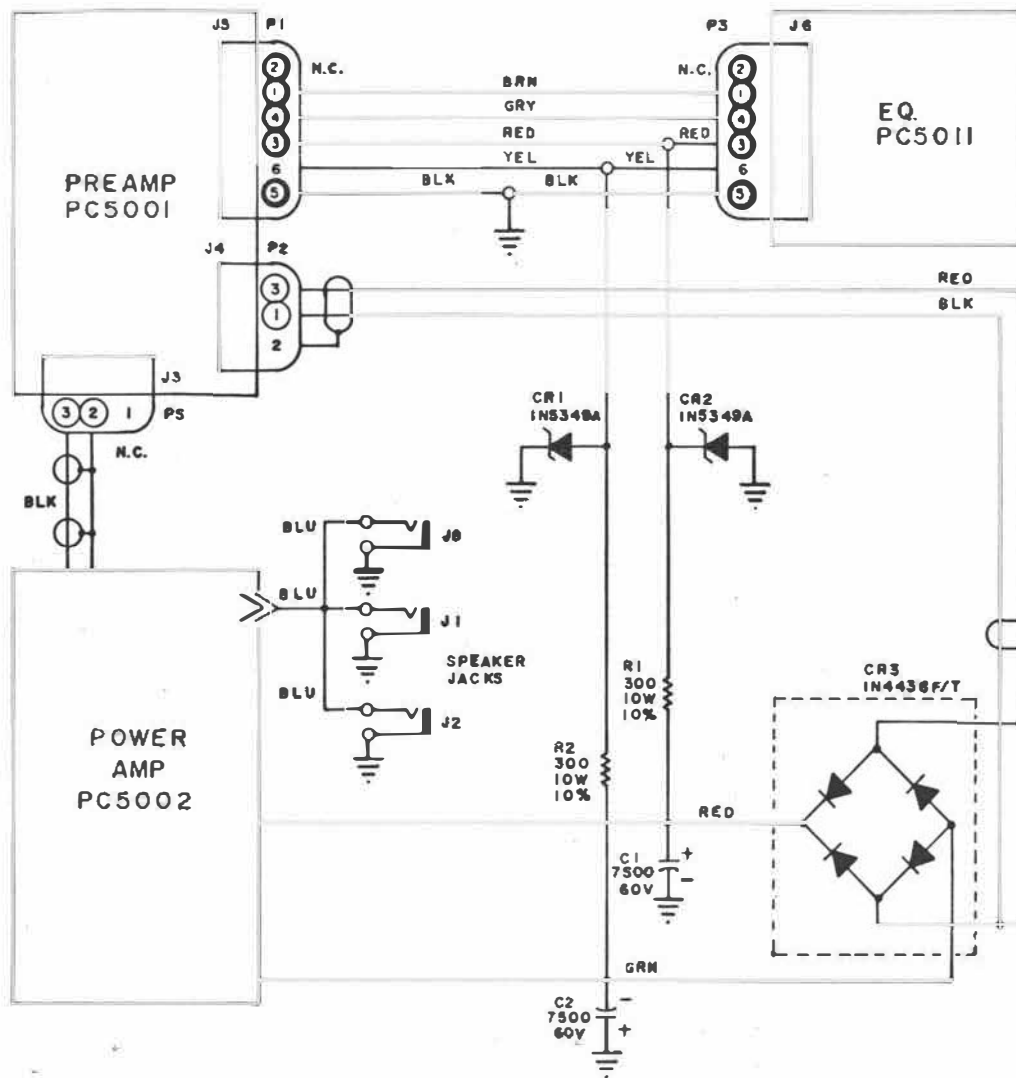

HIGHEST REF NOS DELETED REF NOS.

- DS1
- P5
- J8
- T1
- F1
- SI
- CR3
- C3
- R2

NOTES

1. ALL CAPACITOR VALUES ARE IN MICROFARADS, U.M.

QTY	P/N	DESCRIPTION	ITEM
04			
20			
20			
10			
00			
REV	C.O. DATE BY	<p style="text-align: center; font-size: 2em; font-weight: bold;">ROAD</p> <p>ROAD ELECTRONICS, INC 116 31 W. EXPOSITION BLVD. LOS ANGELES, CAL 90064 (213) 473-6751</p> <p>TOLERANCES U.M. LINEAR XXX: 010 XX: .03 NLS 003 20 1*</p> <p>DATE 10/78</p> <p>QMS DATE</p> <p>DATE</p> <p>DATE</p> <p>SCALE NONE P/N 003-0000-00 SHT 1 OF 1 REV</p>	

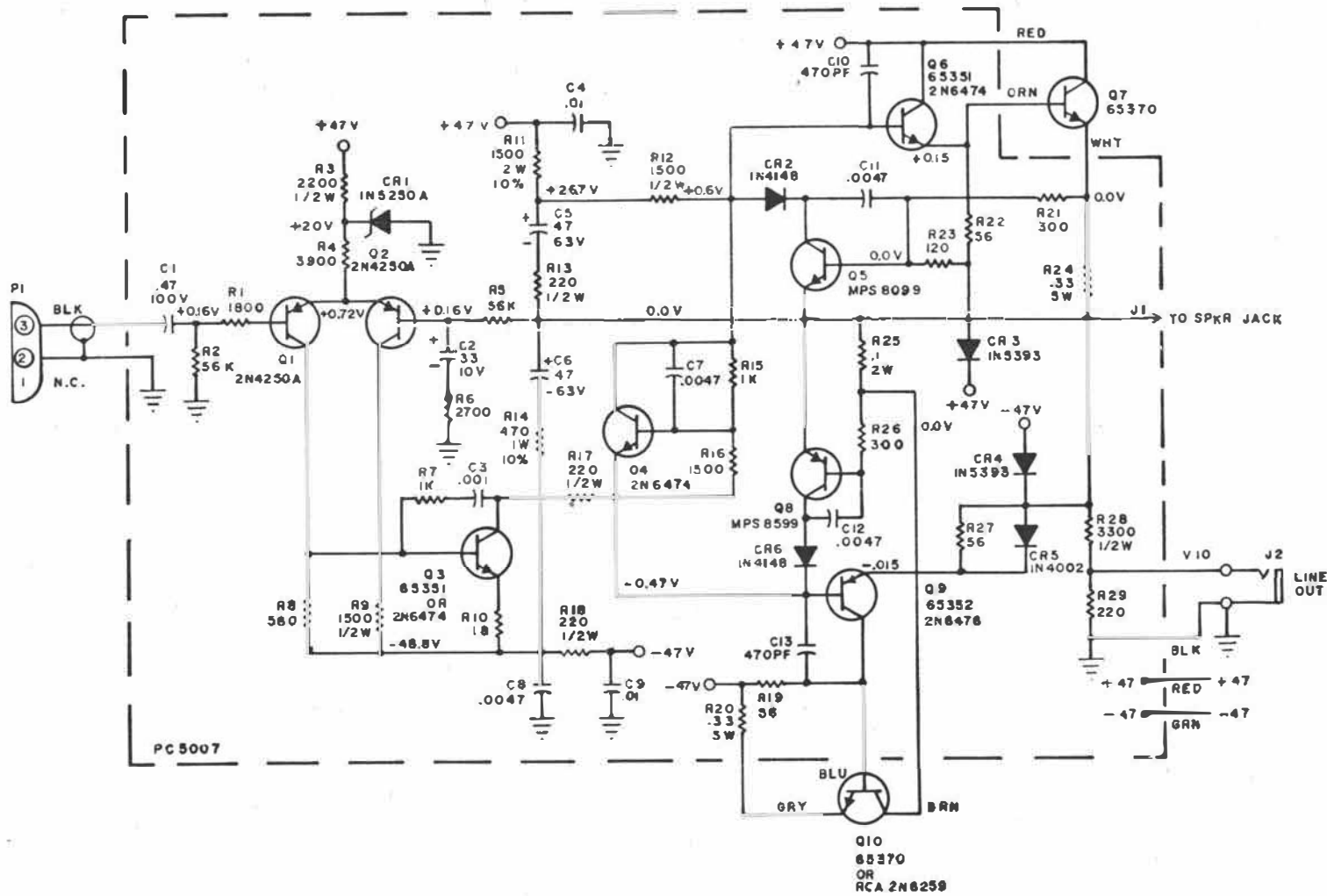

HIGHEST REF NOS DELETED REF NOS

R29
C13
CR6
Q10
P1
J2

NOTES

- 1 ALL CAPACITOR VALUES ARE IN MICROFARADS , U.M.
- 2 ALL RESISTORS ARE 1/4 W, U.N.
- 3 ALL RESISTORS ARE 5% U.N.
- 4 ALL DC VOLTAGES ARE MEASURED WITH 8 OHM LOAD AND NO SIGNAL APPLIED, EXCEPT +47V & -47V SUPPLIES ARE MEASURED AT FULL SINE WAVE POWER OUTPUT INTO 8 OHM LOAD

QTY	P/N	DESCRIPTION	ITEM
	REV	DATE	BY
ROAD		ROAD ELECTRONICS, INC 1631 WEST EXPOSITION BLVD. LOS ANGELES, CA 90064 213 / 473-6751	
TOLERANCES UN. LINE & P. XXX ± .010 XXX ± .005 HLS ± .005 L'S ± 1%			
QTY	DATE	NAME	
QTY	DATE	NAME	100W POWER AMP BD
QTY	DATE	NAME	
SCALE	P/N	QTY	REV
	004 5007 00	1 OF 1	

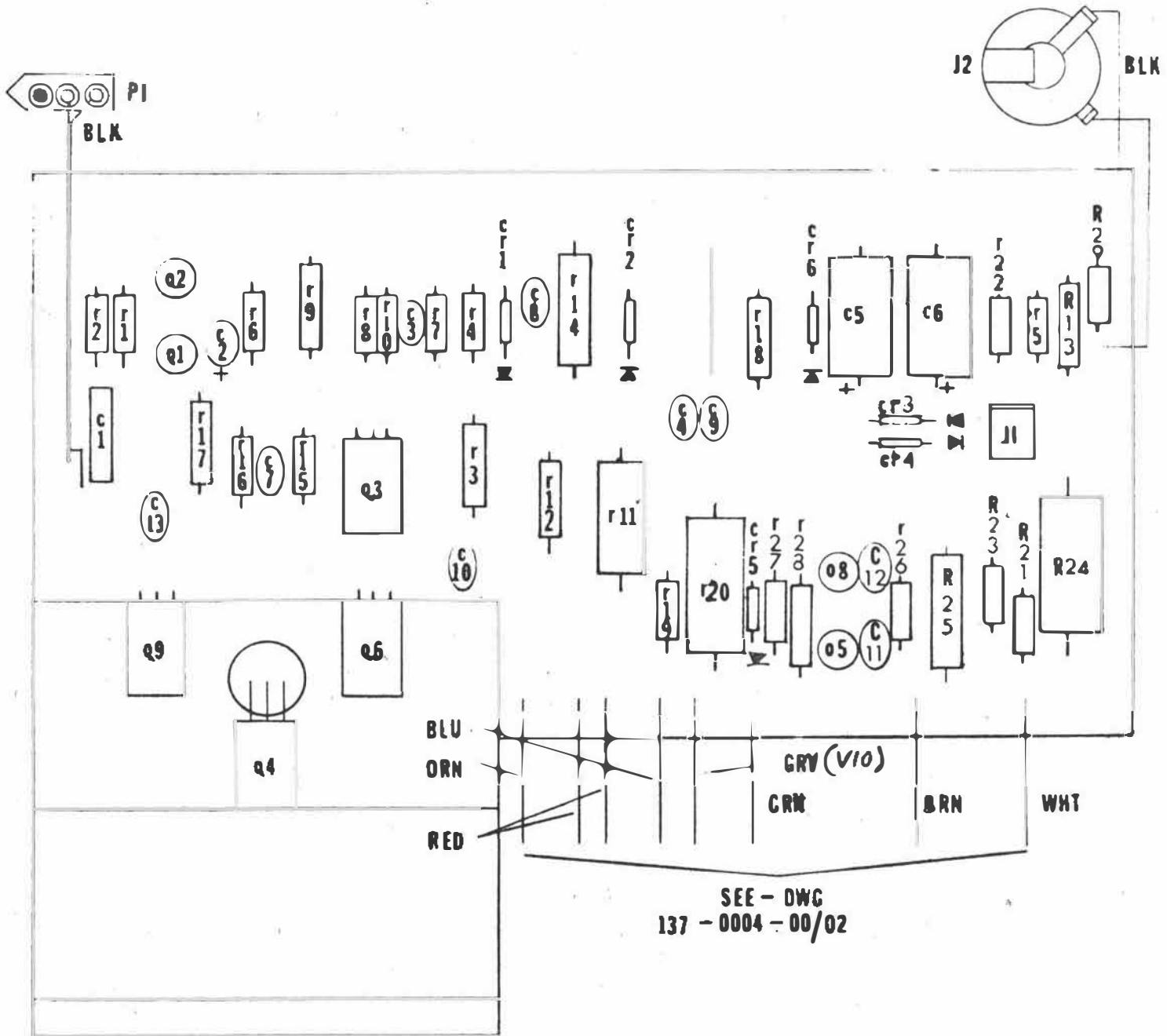

300-5007-00		COMPONENT
100 WATT POWER BOARD		LOCATER
SCALE:	APPROVED BY:	DRAWN BY
DATE:		REVISED
ROAD ELECTRONICS INC.		
		DRAWING NUMBER
		# 21879

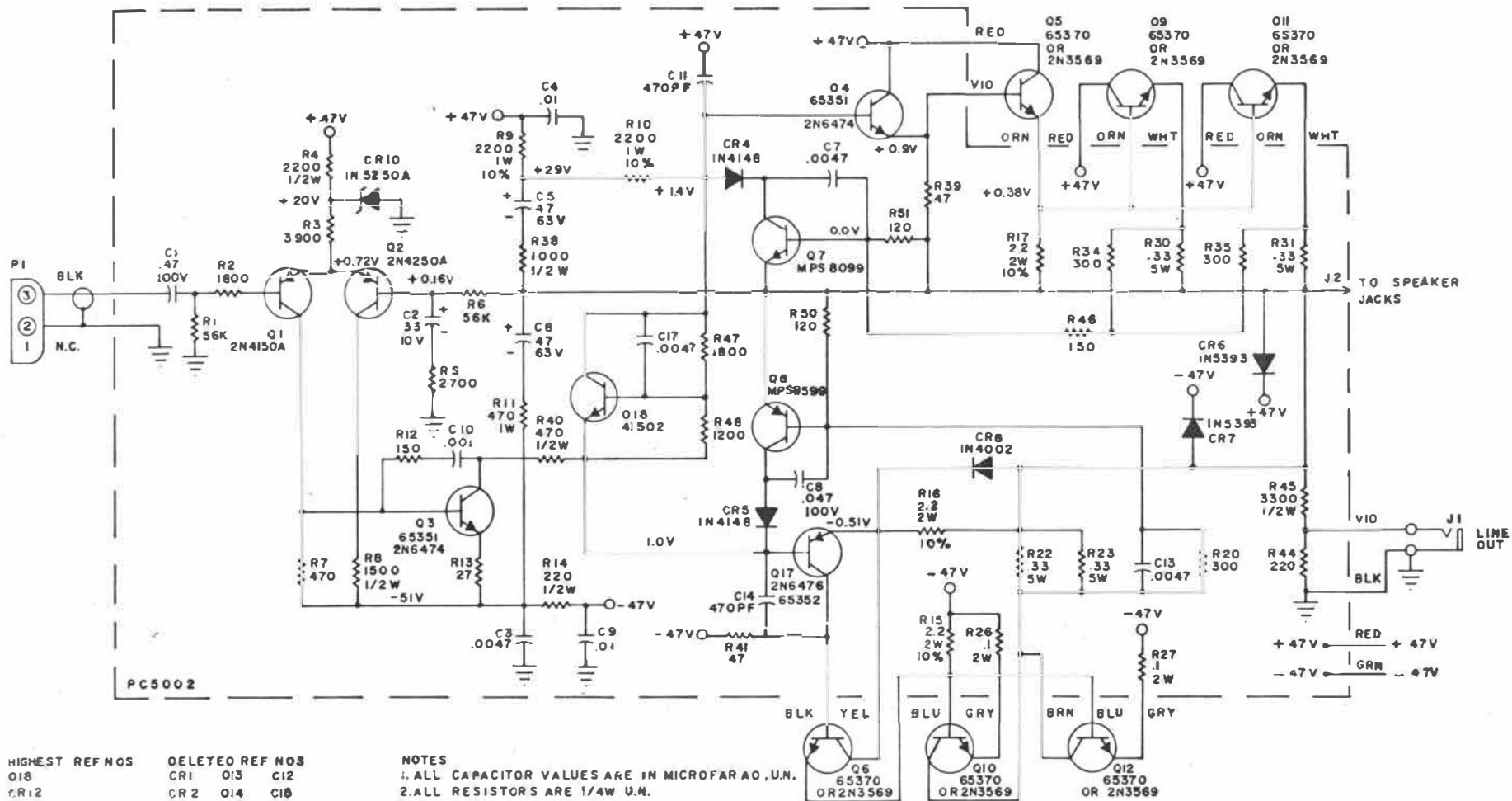

PC5002

HIGHEST REF NOS
 O18
 R12
 Q7
 J2
 P1

DELETED REF NOS
 CR1 O13 C12
 CR2 O14 C18
 CR3 O15 C16
 CR9 O16 R36
 R18 R29 R37
 R24 R32 R42
 R25 R33 R43
 R28 CR6 CR7
 R19 R21

NOTES
 1. ALL CAPACITOR VALUES ARE IN MICROFARAD, U.N.
 2. ALL RESISTORS ARE 1/4W U.N.
 3. ALL RESISTORS ARE 5% U.N.
 4. ALL DC VOLTAGES ARE MEASURED WITH 4 OHM LOAD AND NO SIGNAL APPLIED, EXCEPT +47V & -47V SUPPLIES ARE MEASURED AT FULL SINE WAVE POWER OUTPUT INTO 4 OHM LOAD

QTY	P/N	DESCRIPTION	ITEM
104	REV 01	ROAD	ROAD ELECTRONICS, INC 11631 W EXPOSITION BLVD LOS ANGELES, CALIF 90064 213/473-6751
102	1	1	
101	2	2	
100	3	3	
001	4	4	
	1	1	
	2	2	
	3	3	
	4	4	
	5	5	
	6	6	
	7	7	
	8	8	
	9	9	
	10	10	
	11	11	
	12	12	
	13	13	
	14	14	
	15	15	
	16	16	
	17	17	
	18	18	
	19	19	
	20	20	
	21	21	
	22	22	
	23	23	
	24	24	
	25	25	
	26	26	
	27	27	
	28	28	
	29	29	
	30	30	
	31	31	
	32	32	
	33	33	
	34	34	
	35	35	
	36	36	
	37	37	
	38	38	
	39	39	
	40	40	
	41	41	
	42	42	
	43	43	
	44	44	
	45	45	
	46	46	
	47	47	
	48	48	
	49	49	
	50	50	
	51	51	
	52	52	
	53	53	
	54	54	
	55	55	
	56	56	
	57	57	
	58	58	
	59	59	
	60	60	
	61	61	
	62	62	
	63	63	
	64	64	
	65	65	
	66	66	
	67	67	
	68	68	
	69	69	
	70	70	
	71	71	
	72	72	
	73	73	
	74	74	
	75	75	
	76	76	
	77	77	
	78	78	
	79	79	
	80	80	
	81	81	
	82	82	
	83	83	
	84	84	
	85	85	
	86	86	
	87	87	
	88	88	
	89	89	
	90	90	
	91	91	
	92	92	
	93	93	
	94	94	
	95	95	
	96	96	
	97	97	
	98	98	
	99	99	
	100	100	

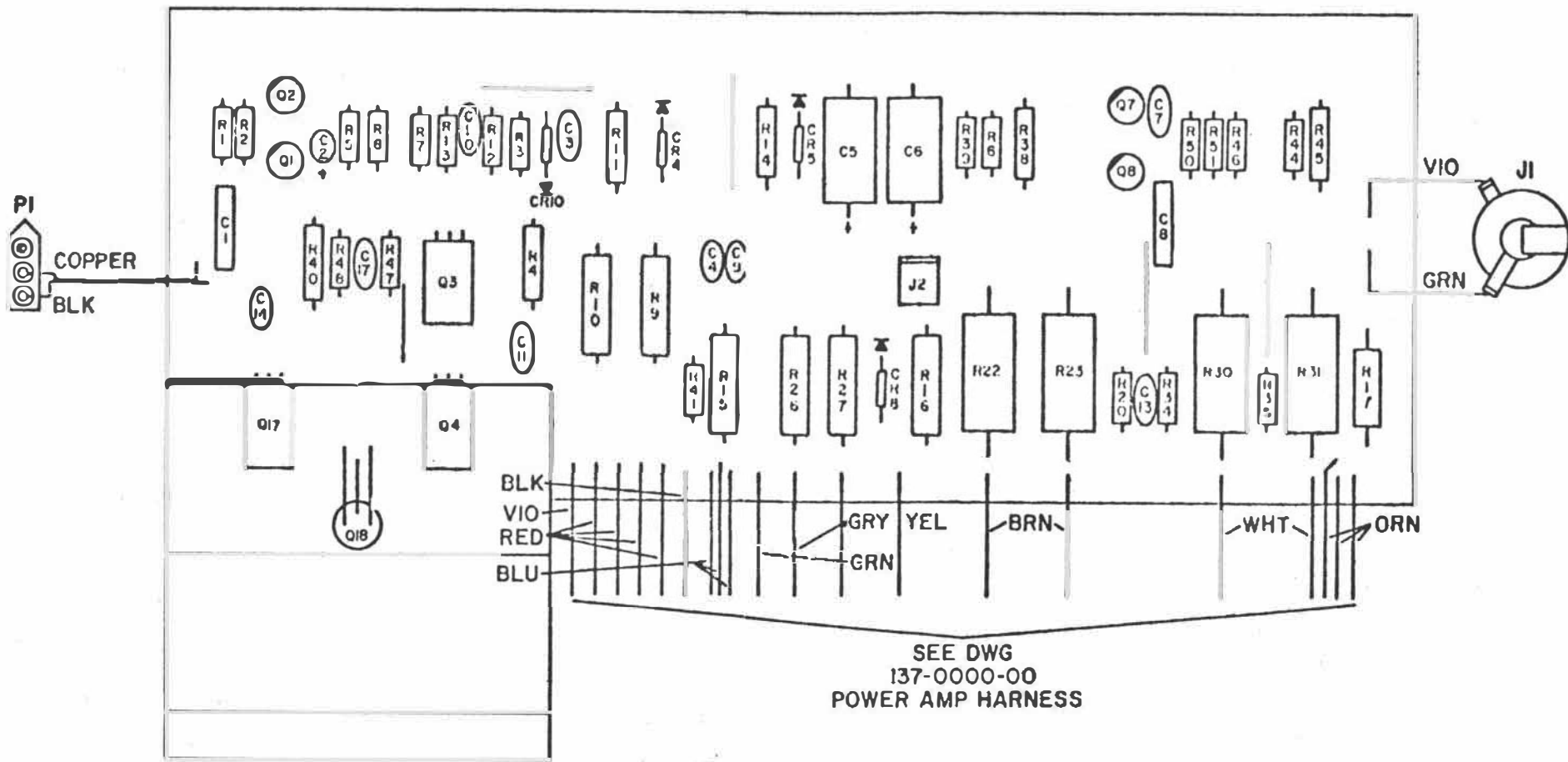

SEE DWG
137-0000-00
POWER AMP HARNESS

QTY				P/N				DESCRIPTION	ITEM
-04	-03	-02	-01	-00	REV	C.O.	DATE	BY	 ROAD ELECTRONICS, INC.
					1	0004	7-75	JS	
TOLERANCES U.N.: LINEAR-.XXX-±010 .XX-±03 HLS-±005 L±-±1°									
				GRN	SCHELL		DATE	2-75	NAME
				CHK			DATE		200W POWER AMP BD
				CHK			DATE		
				SCALE	NONE				P/N 300-5002-00
									SHT 1 OF 1

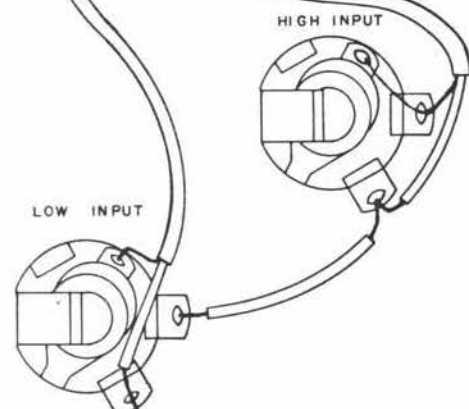
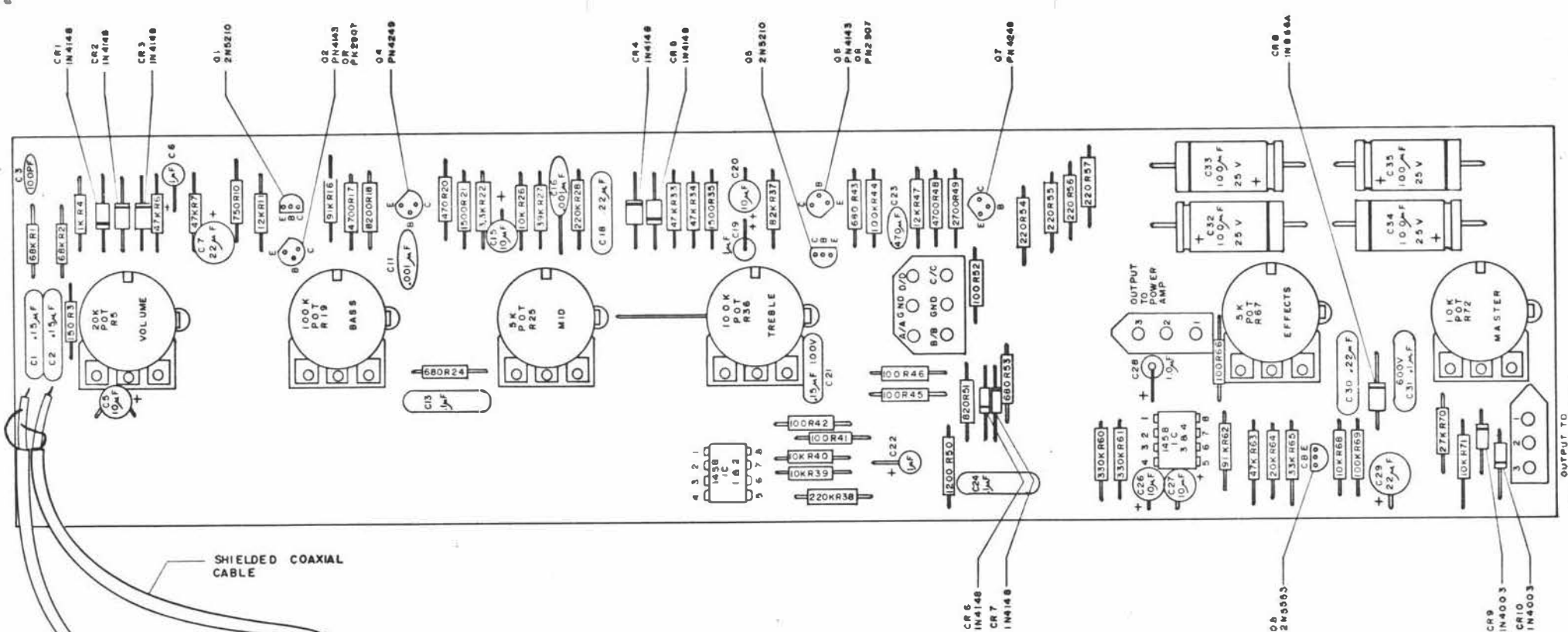

- NOTES
1. ALL CAPACITOR VALUES ARE IN MICROFARADS UNLESS NOTED
 2. ALL RESISTORS ARE 1/4 WATT UNLESS NOTED
 3. ALL RESISTANCE VALUES ARE IN OHMS UNLESS NOTED
 4. ALL TUBULAR CAPACITORS MOUNTED END UP HAVE POSITIVE TERMINAL AWAY FROM THE PC BOARD AS SHOWN BELOW

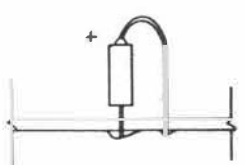

- HIGHEST REF NOS
- R 72
 - C 35
 - CR 8
 - Q 8
 - IC 4
- DELETED REF NOS

QTY	P/N	DESCRIPTION	ITEM
-04	REV	ROAD ELECTRONICS, INC	
-03	CO	11631 W EXPOSITION BLVD	
-02	DATE	LOS ANGELES, CAL 90064	
-01	BY	(213) 473-6761	
-00			
		TOLERANCES UNLESS SPECIFIED: ±0.1% ±0.05% ±0.02% ±0.01% ±0.005%	
	GRN	DATE	
	CHK	DATE	
	CHK	DATE	
	SCALE	P/N	REV
	FULL	5010	1 OF 1

OUTPUT TO POWER TRANSFORMER

- NOTES
 1 ALL CAPACITOR VALUES ARE IN MICROFARADS UNLESS NOTED
 2 ALL RESISTORS ARE 1/4 WATT UNLESS NOTED
 3 ALL RESISTANCE VALUES ARE IN OHMS UNLESS NOTED

HIGHEST REF NOS
 R 72
 C 33
 CR 8
 Q 8
 IC 4

DELETED REF NOS

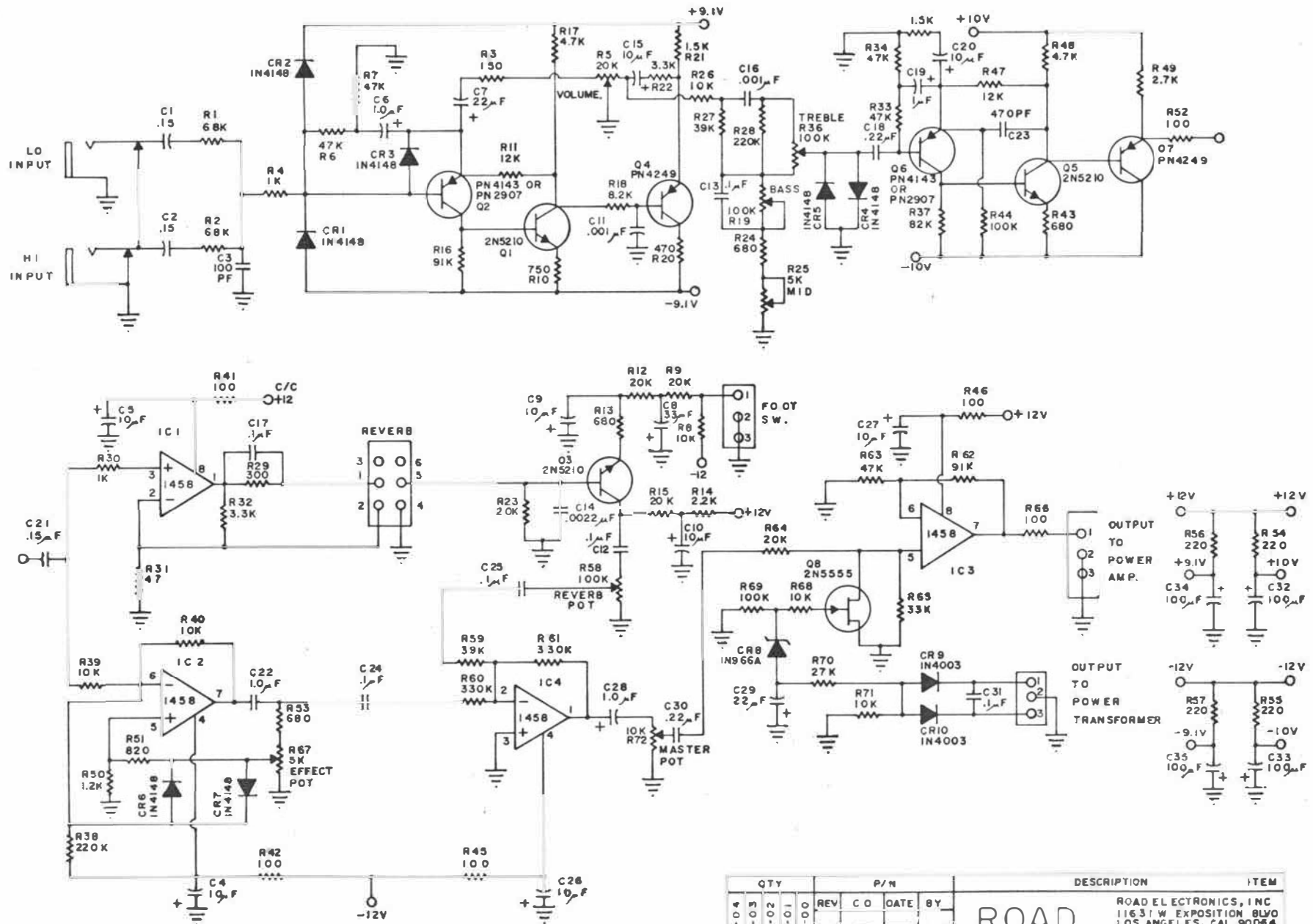

QTY	P/N	DESCRIPTION	ITEM
REV	CO	DATE	BY
01	01		
02			
03			
04			
TOLERANCES UNLESS LINEAR XXX±.010 XX±.03 HLS±.005 L±.1*		ROAD ELECTRONICS, INC 11631 W EXPOSITION BLVD LOS ANGELES, CAL 90064 (213) 473-6781	
DRN	DATE	10/78	
CHK	DATE		
CHK	DATE		
SCALE NONE		P/N	SHT 1 of 1 REV

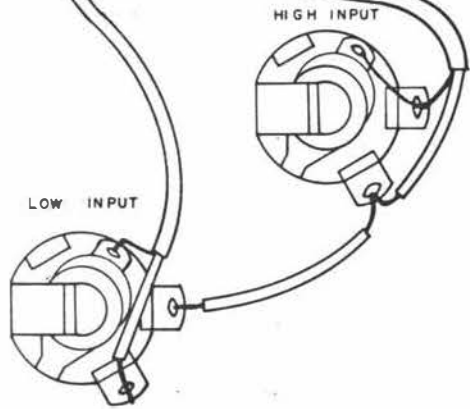
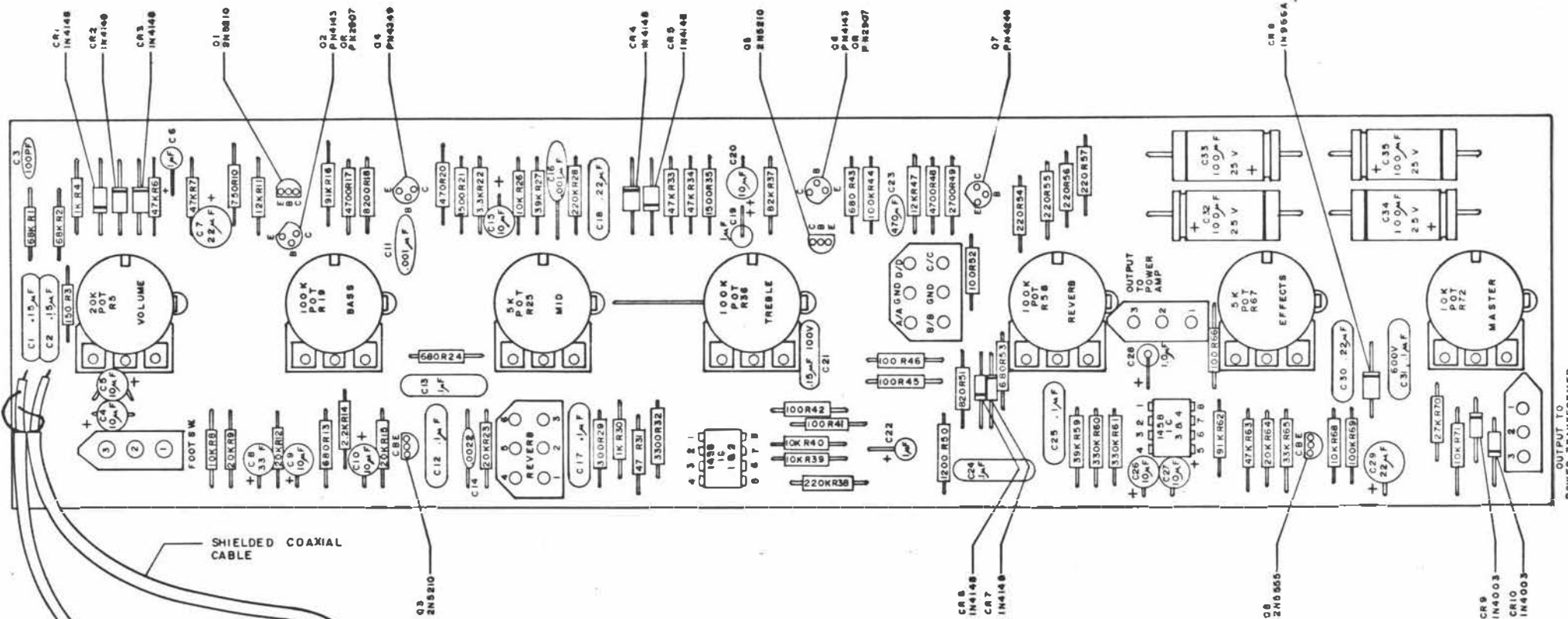

- NOTES
1. ALL CAPACITOR VALUES ARE IN MICROFARADS UNLESS NOTED
 2. ALL RESISTORS ARE 1/4 WATT UNLESS NOTED
 3. ALL RESISTANCE VALUES ARE IN OHMS UNLESS NOTED
 4. ALL TUBULAR CAPACITORS MOUNTED END UP HAVE POSITIVE TERMINAL AWAY FROM THE PC BOARD AS SHOWN BELOW

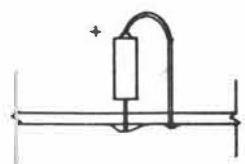

- HIGHEST REF NOS
- R 72
 - C 35
 - CR 8
 - Q 8
 - IC 4
- DELETED REF NOS

QTY	P/N	DESCRIPTION	ITEM
-04	REV	ROAD	ROAD ELECTRONICS, INC
-03	CO		116 31 W. EXPOSITION BLVD.
-02	DATE		LOS ANGELES, CAL 90064
-01	BY		(213) 473-6761
-00			TOLERANCES UNLESS OTHERWISE SPECIFIED: .010 ± .005 .005 ± .001
	DRN	DATE	ROAD 5010 PREAMP
	CHK	DATE	(LEAD MODE L)
	CHK	DATE	
	SCALE	P/N	5010
		SHI	1 OF 1
		REV	